

*Technical Documentation
for PPC Precision Power Chucks*

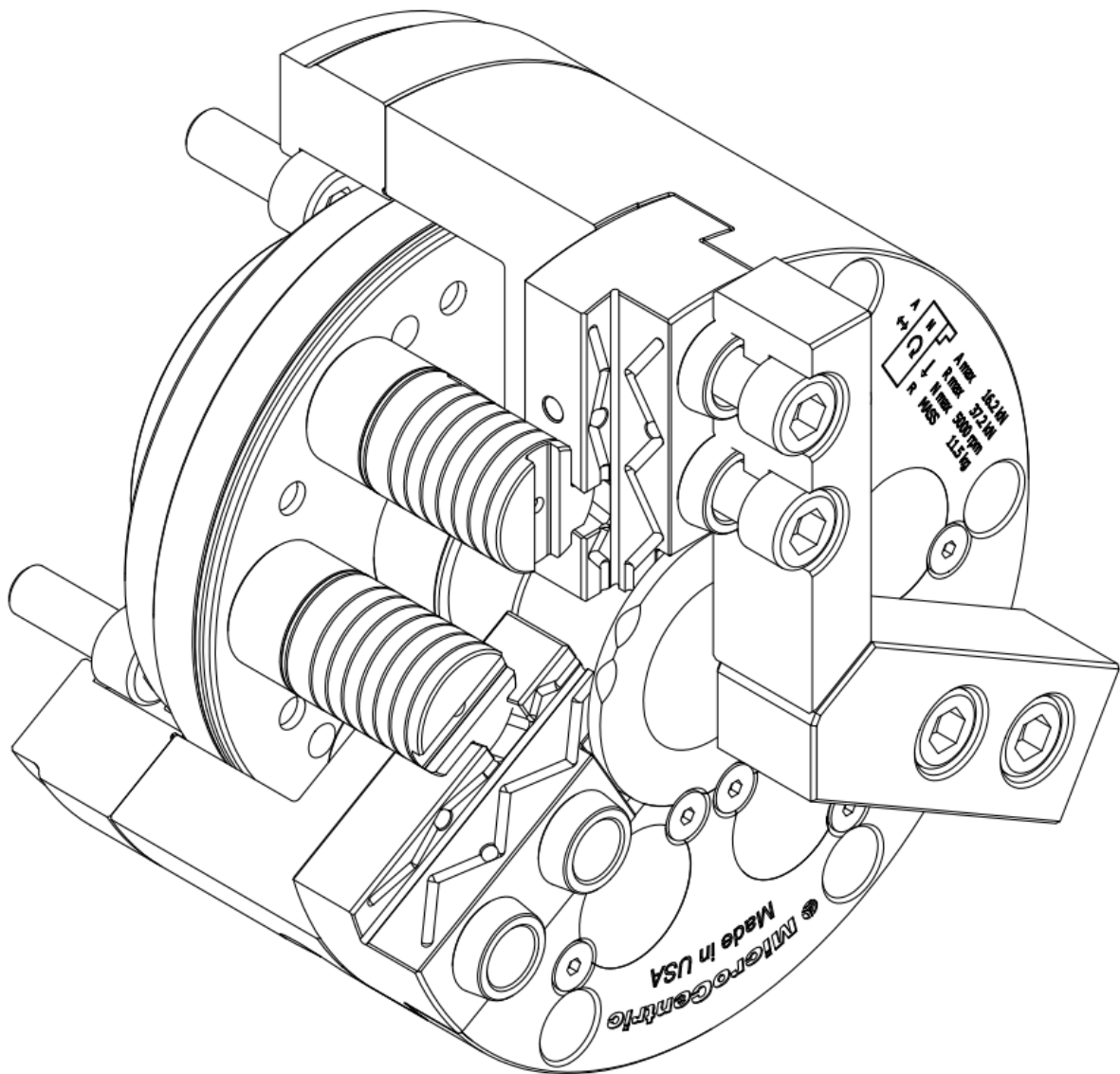

TABLE OF CONTENTS

1.0 Contact & Service Information	2
2.0 Introduction	3
3.0 Precautions for Safe Operation	4
4.0 Recommended Tightening Torque for Mounting Screws	8
5.0 Precision Power Chuck Specifications	9
6.0 Maximum Clamping Force and Spindle Speed	12
6.1 Maximum Static Clamping Force	12
6.2 Maximum Recommended Speed	12
6.3 Effects of Centrifugal Force	12
7.0 Design and Machining of Top Jaws	13
7.1 Top Jaw Design.....	13
7.2 External Chucking Top Jaws	14
7.3 Internal Chucking Top Jaws	14
7.4 Machining Top Jaws.....	15
8.0 Precision Power Chuck System Assembly	16
9.0 Mounting of Chuck	17
9.1 Mounting Adapter Plate	17
9.2 Mounting Chuck Assembly	17
9.3 Mounting Top Jaws	17
10.0 QC Jaw Locating System	18
10.1 QC System Overview	18
10.2 QC Jaw Installation	18
10.3 QC Jaw Removal	18
11.0 Assembly Drawing and Parts List	19
11.1 PPC110D and PPC165D Assembly and Parts List.....	19
11.2 PPC210D, PPC250D, and PPC300D106 Assembly and Parts List	20
12.0 PPC Chuck Maintenance	21
12.1 Lubricating PPC Chucks.....	21
12.2 Frequency of Lubrication	21
12.3 Disassembly of PPC Chucks	21
12.4 Cleaning of PPC Chucks	22
12.5 Reassembly of PPC Chucks.....	22
13.0 Trouble Shooting Guide	23

1.0 CONTACT AND SERVICE INFORMATION

Manufactured by:

MicroCentric Corp.
Plainview, NY USA
www.microcentric.com

Service in North America:

MicroCentric Corp.
25 South Terminal Drive
Plainview, NY 11803 USA
Toll-Free: 1-800-573-1139
Phone: 1-516-349-7220
E-mail: sales@microcentric.com







Service in Europe and Asia:

MicroCentric GmbH
Ringstrasse 134
70839 Gerlingen
Germany
Phone: +49 7156 17819 0
E-mail: info@microcentric.de

2.0 INTRODUCTION

The ultimate High Precision Power Chuck, PPC Series chucks offer unmatched accuracy and long term performance. Their advanced design, high quality hardened alloy steels, and MicroCentric's renowned precision manufacturing capability result in a chuck of unmatched quality.

The information contained in this manual, if properly followed, will enable you to obtain the best possible accuracy and long term performance from your PPC chuck. This manual is also available for download at microcentric.com.

	SAFETY ALERT SYMBOL
	This symbol is used to call attention to items that could be dangerous to you or persons using this equipment. Please read these messages and follow these instructions and safety regulations before use.
	 DANGER
	Indicates an imminent hazardous condition which, if not avoided, could result in serious injury or death.
	 WARNING
	Indicates a potentially hazardous condition which, if not avoided, could result in serious injury or death.
	 CAUTION
	Indicates a potentially hazardous condition which, if not avoided, could result in injury.
	IMPORTANT
	Instructions for optimum performance and avoiding errors or misuse of chuck.

3.0 PRECAUTIONS FOR SAFE OPERATION



DANGER



Switch off power to the machine before installing or changing the chuck.

- The machine spindle may inadvertently be switched on, and the turret indexed or jogged, potentially causing serious injury to the operator.



DANGER



Do not operate the control valve (foot pedal) or solenoid valve during spindle rotation.

- The workpiece will be thrown from the chuck, potentially causing serious injury to the operator.



DANGER



Do not exceed maximum recommended speed of the chuck for a given input pressure.

- The workpiece can be thrown from the chuck due to inadequate gripping force as a result of centrifugal force.



DANGER



Never wear gloves, loose clothing, or ties while operating a machine tool. Secure long hair.

- Gloves, loose clothing, ties, and long hair can become caught in the chuck causing serious injury to the operator as the spindle is rotated.

**DANGER**

Always lift the chuck by using an eyebolt or lifting belt, and stand clear of suspended loads.

- The operator can be injured and the chuck can be damaged if the chuck is dropped.

**WARNING**

Do not start the machine with the door open.

- The operator could be injured by cutting chips or other flying debris.

**WARNING**

Do not exceed the maximum recommended input force (draw tube force) for a specific chuck model.

- The workpiece can be thrown from the chuck as a result of damage to the chucks actuating mechanism.

**WARNING**

Make certain the mounting bolts are securely tightened to the recommended torque values.

- The chuck could become loose during operation causing damage to the chuck and potentially throwing the workpiece from the chuck.



WARNING



Never attempt to operate a machine tool while under the influence of drugs or alcohol.

- Damage to the machine, tooling, and chuck, or serious injury to the operator could result.



WARNING



Remember to lubricate the chuck at regular intervals as specified in this manual.

- The workpiece can be thrown from the chuck due to a loss of gripping force caused by insufficient lubrication.



WARNING



Do not attempt to modify the chuck.

- The workpiece can be thrown from the chuck due to damage which may be caused to the chuck.



WARNING



Long workpieces should be supported by a live center in the tail stock or by a steady rest.

- The workpiece can be thrown from the chuck if it is too long and not properly supported.

**WARNING****Remove eyebolts after use.**

- Rotating the chuck without removing eye bolts may cause them to be thrown from the chuck, potentially causing serious injury.

**WARNING****Disassemble and clean chuck according to Section 12.0.**

- Failure to properly disassemble and clean the chuck can lead to insufficient clamping force, and the workpiece can be thrown from the chuck.

**CAUTION****Ensure workplace is clean.**

- Danger of slipping and falling from a dirty floor, such as lubricants or oil.

**CAUTION****Always make sure to keep your hands and fingers clear of the top jaws and workpiece as the chuck is clamped.**

- The operator can be seriously injured if a finger or hand is clamped between the top jaw and the workpiece.

CAUTION



Do not touch machined workpieces with bare hands.

- Machined workpieces may be very hot, and may cause burns.

CAUTION



Remove workpiece when stopping the machine for an extended period of time.

Clamping force may be lost unexpectedly, causing the workpiece to drop.

CAUTION



Never hit the outside of the chuck, top jaws, or workpiece with a hammer.

- The workpiece can be thrown from the chuck if the chuck is damaged.

4.0 RECOMMENDED TIGHTENING TORQUE FOR MOUNTING SCREWS

SOCKET HEAD CAP SCREW SIZE (CLASS 12.9)	M5	M6	M8	M10	M12	M14	M16	M20
TIGHTENING TORQUE [N*m]	7.5	13	33	73	107	171	250	402
TIGHTENING TORQUE [lb*ft]	5.5	9.6	24	54	79	126	184	297

5.0 PRECISION POWER CHUCK SPECIFICATIONS

PPC110D Specifications

Chuck Model	PPC110D-3	PPC110D-2	PPC110DL-3
Accuracy ¹	.0001"	.0001"	.0001"
	0.0025mm	0.0025mm	0.0025mm
Number of Jaws	3	2	3
Through Hole	1.063"	1.063"	1.063"
	27mm	27mm	27mm
Jaw Stroke ²	.120"	.120"	.180"
	3.0mm	3.0mm	4.6mm
Actuator Stroke	.340"	.340"	.340"
	8.6mm	8.6mm	8.6mm
Max Draw Bar Force	2,090 lbs	1,390 lbs	2,090 lbs
	9.3 kN	6.2 kN	9.3 kN
Max Clamping Force ³	4,600 lbs	3,065 lbs	3,760 lbs
	20.5 kN	13.6 kN	16.7kN
Max Speed ⁴	6,000 rpm	6,000 rpm	5,000 rpm
Chuck Weight ⁵	7.0 lbs	7.0 lbs	7.0 lbs
	3.2 kg	3.2 kg	3.2 kg
Moment of Inertia ⁵	.13 lb-ft ²	.13 lb-ft ²	.13 lb-ft ²
	0.005 kg-m ²	0.005 kg-m ²	0.005 kg-m ²

PPC165D Specifications

Chuck Model	PPC165D-3	PPC165D-2	PPC165DL-3	PPC165DL-2
Accuracy ¹	.0001"	.0001"	.0001"	.0001"
	0.0025mm	0.0025mm	0.0025mm	0.0025mm
Number of Jaws	3	2	3	2
Through Hole	1.375"	1.375"	1.375"	1.375"
	35mm	35mm	35mm	35mm
Jaw Stroke ²	.180"	.180"	.270"	.270"
	4.6mm	4.6mm	6.9mm	6.9mm
Actuator Stroke	.510"	.510"	.510"	0.510
	13.0mm	13.0mm	13.0mm	13.0mm
Max Draw Bar Force	3,640 lbs	2,425 lbs	3,640 lbs	2,425 lbs
	16.2 kN	10.8 kN	16.2 kN	10.8 kN
Max Clamping Force ³	8,370 lbs	5,330 lbs	6,840 lbs	4,515 lbs
	37.2 kN	23.7 kN	30.4 kN	20.1 kN
Max Speed ⁴	5,000 rpm	5,000 rpm	4,000 rpm	4,000 rpm
Chuck Weight ⁵	25.2 lbs	25.2 lbs	25.2 lbs	25.2 lbs
	11.4 kg	11.4 kg	11.4 kg	11.4 kg
Moment of Inertia ⁵	.99 lb-ft ²	.99 lb-ft ²	.99 lb-ft ²	.99 lb-ft ²
	0.04 kg-m ²	0.04 kg-m ²	0.04 kg-m ²	0.04 kg-m ²

PPC210D Specifications

Chuck Model	PPC210D-3	PPC210D-2	PPC210DL-3	PPC210DL-2
Accuracy ¹	.0001" 0.0025mm	.0001" 0.0025mm	.0001" 0.0025mm	.0001" 0.0025mm
Number of Jaws	3	2	3	2
Through Hole	2.050" 52mm	2.050" 52mm	2.050" 52mm	2.050" 52mm
Jaw Stroke ²	.220" 5.6mm	.220" 5.6mm	.340" 8.6mm	.340" 8.6mm
Actuator Stroke	.630" 16.0mm	.630" 16.0mm	.630" 16.0mm	.630" 16.0mm
Max Draw Bar Force	5,840 lbs 26.0 kN	3,890 lbs 17.3 kN	5,840 lbs 26.0 kN	3,890 lbs 17.3 kN
Max Clamping Force ³	13,430 lbs 59.7 kN	8,950 lbs 39.8 kN	10,510 lbs 46.8 kN	7,000 lbs 31.1 kN
Max Speed ⁴	4,500 rpm	4,500 rpm	3,500 rpm	3,500 rpm
Chuck Weight ⁵	44.3 lbs 20.1 kg	44.3 lbs 20.1 kg	44.3 lbs 20.1 kg	44.3 lbs 20.1 kg
Moment of Inertia ⁵	2.87 lb-ft ² 0.12 kg-m ²	2.87 lb-ft ² 0.12 kg-m ²	2.87 lb-ft ² 0.12 kg-m ²	2.87 lb-ft ² 0.12 kg-m ²

PPC250D Specifications

Chuck Model	PPC250D-3	PPC250D-2	PPC250DL-3	PPC250DL-2
Accuracy ¹	.0002" 0.005mm	.0002" 0.005mm	.0002" 0.005mm	.0002" 0.005mm
Number of Jaws	3	2	3	2
Through Hole	2.600" 66mm	2.600" 66mm	2.600" 66mm	2.600" 66mm
Jaw Stroke ²	.250" 6.3mm	.250" 6.3mm	.380" 9.6mm	.380" 9.6mm
Actuator Stroke	.710" 18.0mm	.710" 18.0mm	.710" 18.0mm	0.710 18.0mm
Max Draw Bar Force	7,100 lbs 31.6 kN	4,730 lbs 21.0 kN	7,100 lbs 31.6 kN	4,730 lbs 21.0 kN
Max Clamping Force ³	16,330 lbs 72.6 kN	10,875 lbs 48.4 kN	12,780 lbs 56.8 kN	8,515 lbs 37.9 kN
Max Speed ⁴	3,500 rpm	3,500 rpm	2,500 rpm	2,500 rpm
Chuck Weight ⁵	74.2 lbs 33.7 kg	74.2 lbs 33.7 kg	74.2 lbs 33.7 kg	74.2 lbs 33.7 kg
Moment of Inertia ⁵	7.03 lb-ft ² 0.30 kg-m ²	7.03 lb-ft ² 0.30 kg-m ²	7.03 lb-ft ² 0.30 kg-m ²	7.03 lb-ft ² 0.30 kg-m ²

PPC300D106 Specifications

Chuck Model	PPC300D106-3	PPC300D106-2	PPC300DL106-3	PPC300DL106-2
Accuracy ¹	.0002"	.0002"	.0002"	.0002"
	0.005mm	0.005mm	0.005mm	0.005mm
Number of Jaws	3	2	3	2
Through Hole	4.170"	4.170"	4.170"	4.170"
	106mm	106mm	106mm	106mm
Jaw Stroke ²	.250"	.250"	.380"	.380"
	6.3mm	6.3mm	9.6mm	9.6mm
Actuator Stroke	.710"	.710"	.710"	0.710
	18.0mm	18.0mm	18.0mm	18.0mm
Max Draw Bar Force	8,270 lbs	5,510 lbs	8,270 lbs	5,510 lbs
	36.8 kN	24.5 kN	36.8 kN	24.5 kN
Max Clamping Force ³	21,580 lbs	14,240 lbs	16,830 lbs	11,110 lbs
	95.9 kN	63.6 kN	74.9 kN	49.4 kN
Max Speed ⁴	2,800 rpm	2,800 rpm	2,000 rpm	2,000 rpm
Chuck Weight ⁵	100.8 lbs	100.8 lbs	100.8 lbs	100.8 lbs
	45.7 kg	45.7 kg	45.7 kg	45.7 kg
Moment of Inertia ⁵	14.5 lb-ft ²	14.5 lb-ft ²	14.5 lb-ft ²	14.5 lb-ft ²
	0.61 kg-m ²	0.61 kg-m ²	0.61 kg-m ²	0.61 kg-m ²

1 - Accuracy is the total indicator reading (radial and lateral runout) of a master gage measured 1.00" (25.4mm) from the top face of the standard top jaw at 1/2 max draw tube force.

2 - Total jaw stroke.

3 - Total clamping force.

4 - Maximum speed with standard top jaw at max draw tube force.

5 - Without top jaws and spindle mounting plate.

6.0 MAXIMUM CLAMPING FORCE AND SPINDLE SPEED

6.1 MAX. STATIC CLAMPING FORCE

The static clamping force developed by PPC chucks will vary depending on several variables including the state of lubrication of the chuck, the type of grease used, the height of the top jaws, among other factors. MicroCentric's standard specifications for PPC chucks are based on the following conditions:

1. A standard height top jaw is used.
2. Jaw force is measured at the mid point (in height) of a standard jaw blank, at mid stroke with a jaw force gage.
3. MicroCentric's recommended grease is used to obtain maximum efficiency of the chuck.
4. The mounting bolts on the top jaws are tightened to the specified torque.
5. The recommended draw tube force is applied to the chuck.

6.2 MAX. RECOMMENDED SPEED

The maximum recommended speed for PPC chucks is defined as the speed at which the measured clamping force during rotation is reduced by 2/3 of the static value. Dynamic clamping force is measured under the following conditions:

1. A standard jaw height is used.
2. Jaw force is measured at the mid point (in height) of a standard jaw blank, at mid stroke with a dynamic jaw force gage.
3. The chuck is sufficiently lubricated with MicroCentric's recommended grease to obtain maximum efficiency of the chuck.
4. The mounting bolts on the top jaws are tightened to the specified torque.
5. The maximum recommended draw tube force is applied to the chuck.

6.3 CENTRIFUGAL FORCE

Centrifugal force acts on the chuck jaws during rotation. It is important to always reduce the weight of the top jaw as much as possible for each application to minimize the effects of centrifugal force, and consequently, the loss of clamping force during rotation.

IMPORTANT

Always reduce the weight of the top jaw as much as possible to minimize the clamping force loss as the chuck rotates.

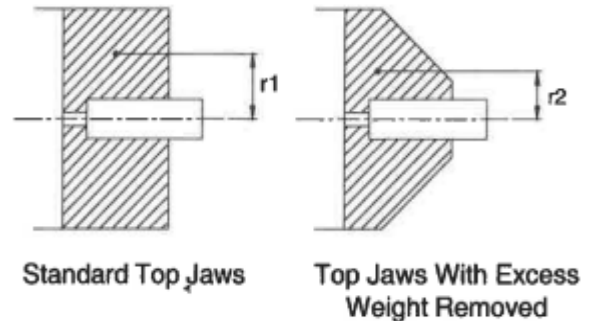

CAUTION

When using top jaws which are taller and more massive than the standard jaw, a greater amount of clamping force will be lost due to centrifugal force which acts on the top jaw. The maximum recommended speed under these conditions will be less than the value for the standard top jaws.

7.0 DESIGN AND MACHINING OF TOP JAWS

7.1 TOP JAW DESIGN

Top jaw design is one of the most important elements in the overall performance, accuracy, and efficiency of a workholding system. To achieve the maximum possible accuracy, as well as optimize the chuck's clamping capability, the following points should be considered in the design and machining of top jaws.

1. A workpiece must have an accurately machined holding diameter, in terms of size tolerance, roundness, and perpendicularity to the locating surface, for precise chucking.
2. When chucking thin walled workpieces, the size and roundness tolerances of the holding diameter will determine the degree to which the workpiece is distorted during chucking, and how accurately the workpiece can be machined.
3. The workpiece should be clamped as close to the face of the chuck as possible.
4. The clamping surfaces of the workpiece and top jaws must have smooth surface finishes, and must be absolutely clean and free of burrs.
5. For external clamping applications, the mass of the top jaws should be reduced as much as possible to minimize the effects of centrifugal force. It is especially important to reduce weight at the largest radius. Refer to Figure 7.1.

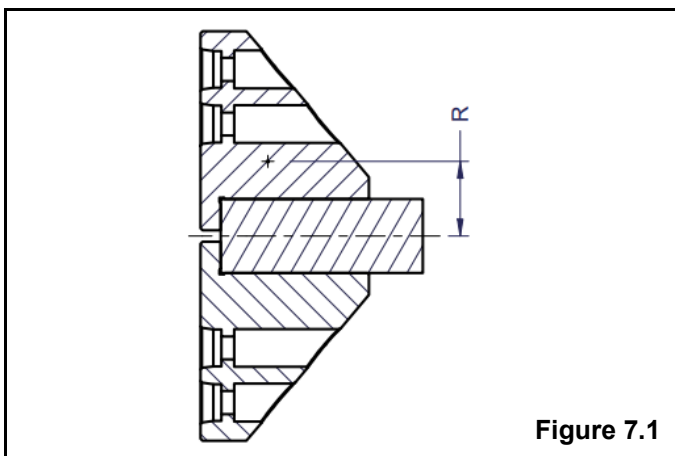

6. Short workpieces must have a square locating face on which they are clamped, in order to ensure the part is clamped accurately. Refer to Figure 7.2.

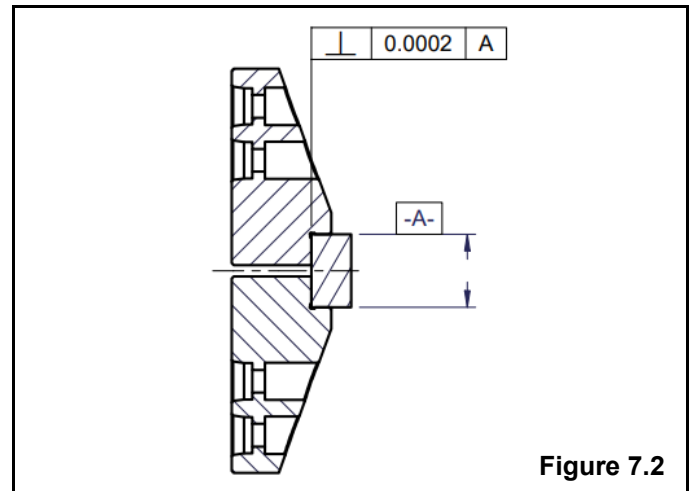

7. Workpieces with no shoulder support must be clamped on a length twice their diameter. Refer to Figure 7.3.

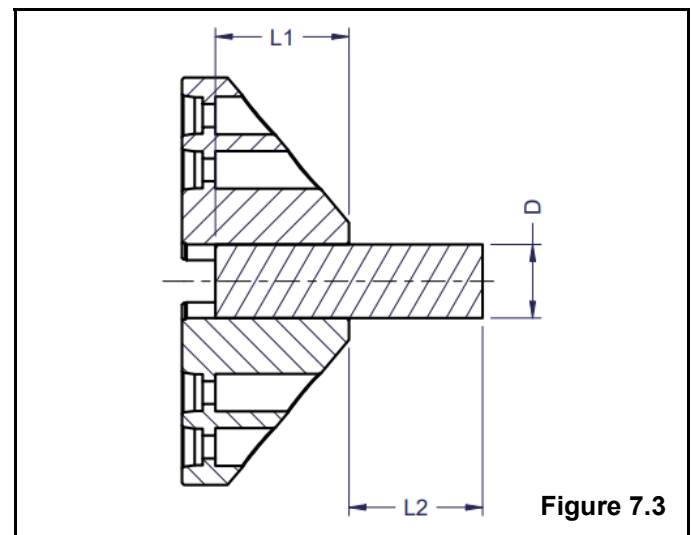

8. Long workpieces should not extend beyond the face of the top jaws more than one and one half times the length being clamped, unless an end support is used. Refer to Figure 7.3.

9. In situations where the top jaws' counter bored mounting bolt holes interfere with the clamping diameter, it is very important that the top jaw's clamping diameter is machined to the exact diameter of the workpiece diameter. Otherwise two-line contact occurs during clamping as shown in Figure 7.4, which will result in a loss of chucking accuracy.

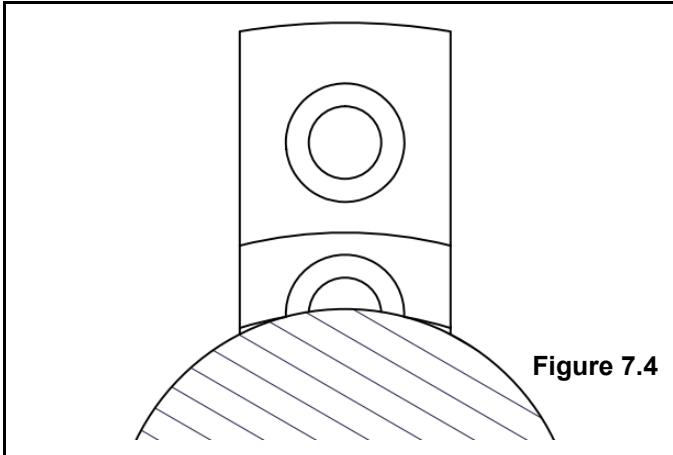

7.2 EXTERNAL CHUCKING TOP JAWS

1. For external chucking applications, the clamping diameter of the top jaws should be equal to or slightly larger than the upper tolerance limit of the workpiece's clamping diameter.
2. When the workpiece's clamping diameter is smaller than the top jaws' clamping diameter, line contact occurs during clamping as illustrated in Figure 7.5. This condition is acceptable and will produce accurate and concentric workholding.
3. If the workpiece's clamping diameter is larger than the top jaw's clamping diameter, a two-line contact occurs during clamping as shown in Figure 7.6. This condition is beneficial for high clamping force applications, but usually results in a loss of chucking accuracy.

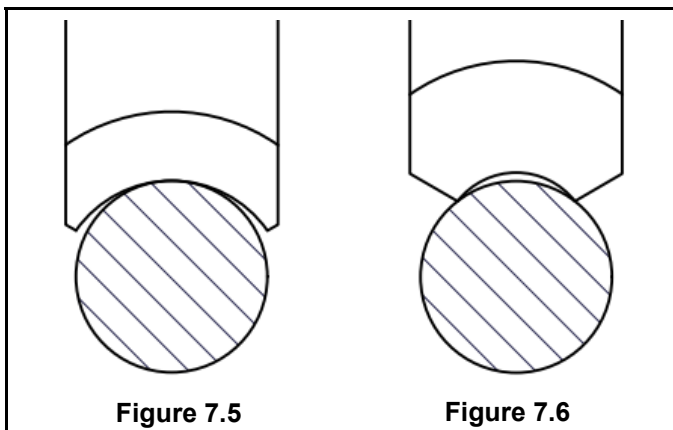

7.3 INTERNAL CHUCKING TOP JAWS

1. For internal clamping applications, the clamping diameter of the top jaws should be equal to or smaller than the lower tolerance limit of the workpiece's clamping diameter.
2. When the workpiece's clamping diameter is larger than the top jaws' clamping diameter, a line contact occurs during clamping as shown in Figure 7.7. This condition is acceptable and will produce accurate and concentric workholding.
3. If the workpiece's clamping diameter is smaller than the top jaws' clamping diameter, two line contact occurs during clamping as shown in Figure 7.8. This condition is beneficial for high clamping force applications, but results in a loss of chucking accuracy.

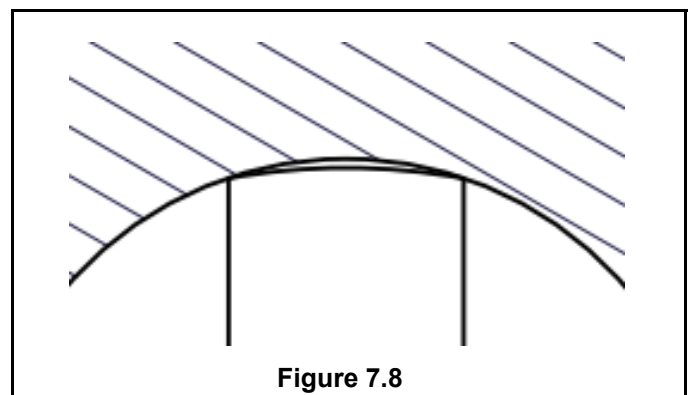
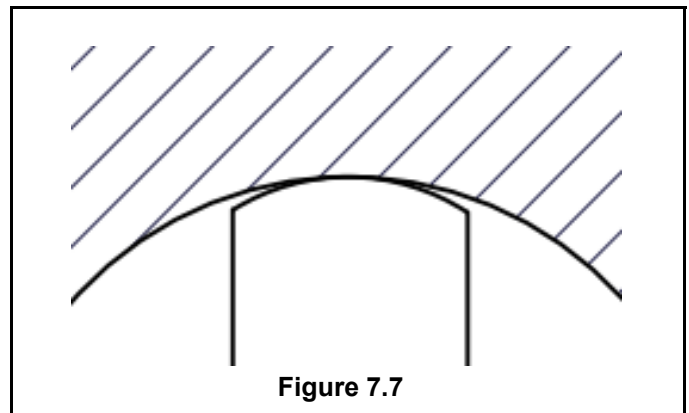

7.4 MACHINING OF TOP JAWS

To achieve the best possible chucking accuracy, it is necessary to finish machine the clamping diameter and locating face of the top jaws on the chuck, under load. The method by which the jaws are loaded, together with the surface finish of the clamping and locating surfaces, as well as the size of the clamping diameter, will determine the overall accuracy and clamping capability of the chuck. Consider the following when machining top jaws:

1. Always load the chuck in the same direction the chuck is clamping. For OD holding applications the chuck must be closed on a loading pin or ring. For ID applications the chuck must open on a loading ring.
2. The position at which the chuck is loaded during machining of the top jaws, determines the position within the total stroke of the chuck that the workpiece will be clamped. Top jaws should be machined at the upper end of the chuck's stroke (closer to full open) to permit re-boring of the jaws. Re-boring of the jaws can be accomplished by loading the chuck further down in the stroke with a smaller diameter pin or ring.
3. Loading the top jaws further down in the chuck's stroke (near fully closed) allows greater clearance for applications where the workpiece is automatically loaded. An opening of .040" (1mm) on diameter is recommended for automatic loading.
4. Top jaws should be machined at the same air pressure which will be used to clamp the workpiece during production. In instances where either the loading ring or the top jaws are subject to deflection during loading, it is recommended that the top jaws be machined at an air pressure lower than that to be used during production.
5. Several recommended loading configurations are illustrated in Figures 7.9, 7.10, and 7.11 for OD clamping applications and 7.12 for ID clamping. The loading configuration shown in 7.10 should not be used with top jaws exceeding 2.00" (50mm) in height.
6. Carefully clean the mounting surfaces of the master jaws and top jaws before mounting the top jaws to the chuck. The top jaws should fit snugly on the locating pins or QC buttons. On dowel pin located jaws, first tighten the jaw mounting screws lightly, then clamp the loading pin or ring several times with light air pressure to assure that the top jaws are

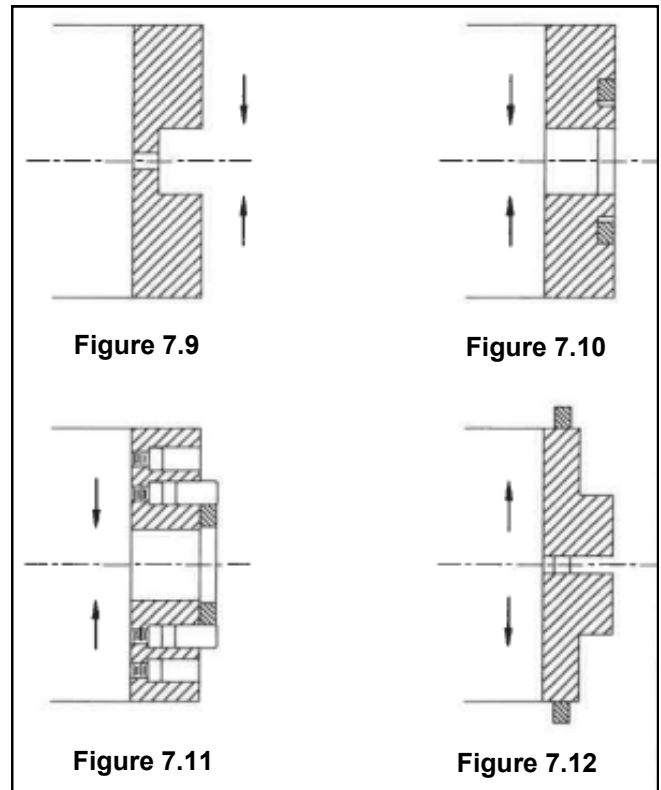

properly seated. With the chuck clamped on the loading pin, tighten the mounting bolts to the torque specifications given in Section 4.0. On QC located jaws just tighten the mounting bolts after they are installed on the chuck.

7. Top jaws can be rough machined on a turning fixture, but should be finish machined under load on the chuck to achieve best chucking accuracy.
8. Dowel pin located top jaws must be re-machined when they are reinstalled on the chuck to achieve best chucking accuracy.
9. When top jaws are finished on a machine other than the one used in production, it is necessary to establish a true reference diameter and face which is to be indicated when mounting the chuck.

8.0 PRECISION POWER CHUCK SYSTEM ASSEMBLY

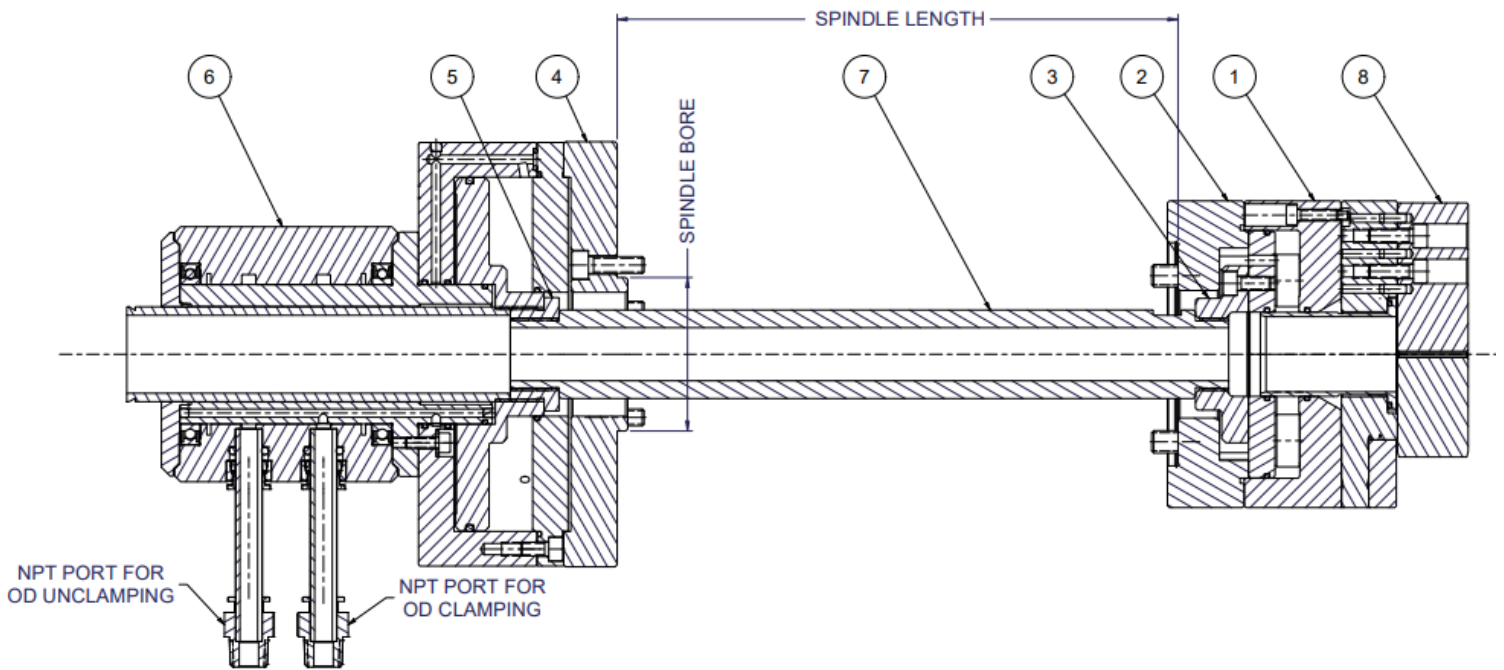

ITEM	QTY	TITLE
1	1	POWER CHUCK
2	1	ADAPTER
3	1	DRAW TUBE CONNECTOR
4	1	CYLINDER ADAPTER
5	1	BUSHING (OPTIONAL)
6	1	ACTUATOR (HYDRAULIC OR PNEUMATIC)
7	1	DRAW TUBE
8	3	TOP JAW BLANK

9.0 MOUNTING OF CHUCK

PPC chucks are supplied with a mounting plate and threaded draw tube connector to suit the machine configuration specified when the chuck was ordered. Refer to the chuck assembly drawing (on page 16) to familiarize yourself with the chuck's components before mounting the chuck.

9.1 MOUNTING ADAPTER PLATE

1. Make certain that the spindle and mounting plate are clean and free of nick, burrs, and foreign materials which would prevent the proper seating of the adapter plate.
2. Mount the adapter plate to the machine spindle. Do not fully tighten the mounting bolts at this time. First indicate the radial runout of the pilot diameter, and lateral runout of the mounting face as described in step 3.
3. Use a dial indicator to measure the radial and lateral runout of the mounting surfaces of the adapter plate. Both radial and face runout should not exceed $.0002''$ (0.010mm). Adjust the radial runout to within $.0002''$ (0.010mm) before fully tightening the mounting bolts. If the face runout exceeds $.0002''$ (0.010mm), remove the adapter from the spindle nose and verify that the adapter plate is seating properly and is clean and free of nicks and burrs. A skim cut can be taken on the mounting face of the adapter once it is mounted to the spindle to assure the face is running true.
4. Tighten the mounting bolts alternately to the torque specifications given in Section 4.0.

9.2 MOUNTING CHUCK ASSEMBLY

1. Verify that the draw tube pressure is set to a value within the chuck's limit, adjust draw tube pressure if necessary, and actuate the draw tube to bring it into the forward position.
2. Thread the draw tube connector onto the draw tube. On PPC110 and PPC165 models, thread the connector until the thread bottoms out. On PPC210 and larger chuck models, first remove the center housing from the chuck body, and using the wrench supplied with the chuck, thread the draw tube connector onto the draw tube. Thread the connector fully onto the draw tube then back off the thread until the detents are fully engaged.
3. Actuate the draw tube to seat the chuck onto the adapter plate, aligning the mounting bolts in the body with the mounting holes on the adapter plate.

4. Tighten the mounting bolts alternately but do not fully tighten them at this point.
5. Indicate the OD of the chuck body and adjust the runout to within $.0002''$ (0.005mm) TIR.
6. After the runout of the chuck's OD has been adjusted, tighten the mounting bolts to the torque specifications given in Section 4.0.
7. Actuate the draw tube to verify that the chuck is functioning properly by measuring the stroke of each jaw. If the jaws do not make their full stroke, check that the draw tube is not being restricted, the draw tube data that was specified when the chuck was ordered is correct, or that the draw tube connector was correctly manufactured.

9.3 MOUNTING TOP JAWS

1. Make certain that the mating faces are clean and free of nick, burrs, and foreign materials which would prevent the proper seating of jaws.
2. Be sure to assemble the correct numbered top jaw to each corresponding master jaw.
3. Tighten the mounting bolts alternately, to the torque specifications given in Section 4.0.
4. Ensure that the bottom surface of each top jaw is flush to the top surface of each master jaw.

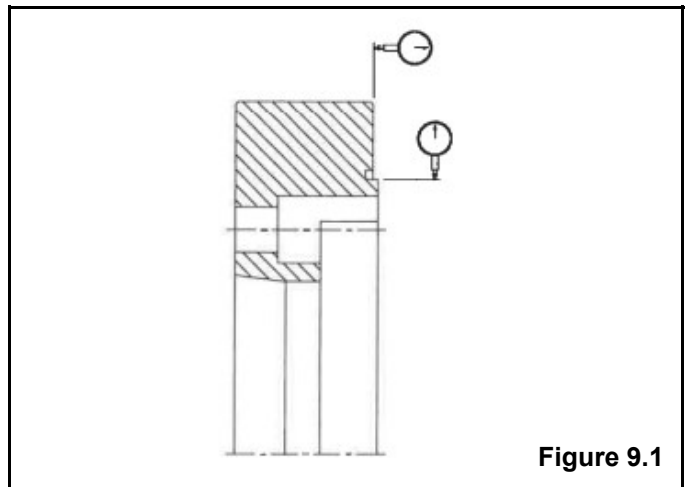

IMPORTANT

The runout of the mounting plate should not exceed $.0002''$ (.010mm) radially, and $.0001''$ (.005mm) laterally. The runout of the OD of the chuck body should not exceed $.0002''$ (.010mm).

10.0 QC JAW LOCATING SYSTEM

10.1 QC SYSTEM OVERVIEW

The QC system locates each top jaw on two tapered buttons mounted in each master jaw. The top jaw is located on both the taper and the face of the master jaw to effectively eliminate any clearances between the master jaw and the top jaw. This feature assures accurate relocation of the top jaw when repositioned on the chuck.

10.2 QC JAW INSTALLATION

1. First make sure that the locating surfaces of the top jaws, master jaws, and QC buttons are completely clean and free from nicks, burrs, or any foreign matter which would prevent proper seating of the top jaws.
2. It is advised that each top jaw be stamped or marked 1, 2, and 3 so that they can be mounted to the correspondingly marked master jaw for later reference.
3. Mount the top jaw no. 1 onto master jaw no. 1.
4. Insert the mounting screws into the top jaw and tighten each screw to the torque specifications given in Section 4.0.

10.3 QC JAW REMOVAL

1. First loosen the mounting screws from jaw no. 1 and then remove the screws completely from the top jaw.
2. The top jaw may remain locked onto the tapered buttons on the master jaw. To break the top jaw free, tap the end of the top jaw lightly with a soft hammer. Tap the jaw toward the center of the chuck while holding the sides of the top jaw.
3. Repeat this procedure for the other top jaws.

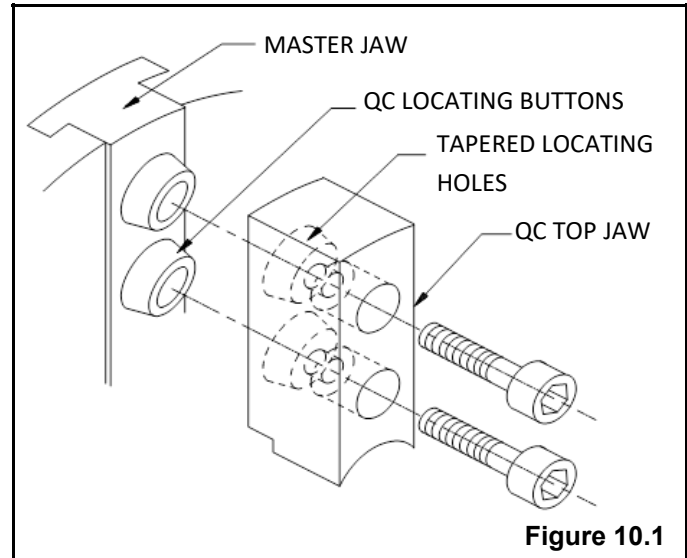

IMPORTANT

The mounting surfaces of the top jaws, master jaws, and QC buttons must be clean and be free of nicks or any foreign matter, otherwise the top jaws will not seat properly which will result in excessive runout.



CAUTION

In order to minimize jaw runout, it is critical that the mounting screws of the top jaws are tightened to the torque specifications given in Section 4.0

11.0 PPC ASSEMBLY DRAWING AND PARTS LIST

11.1 PPC110 AND PPC165 ASSEMBLY AND PARTS LIST

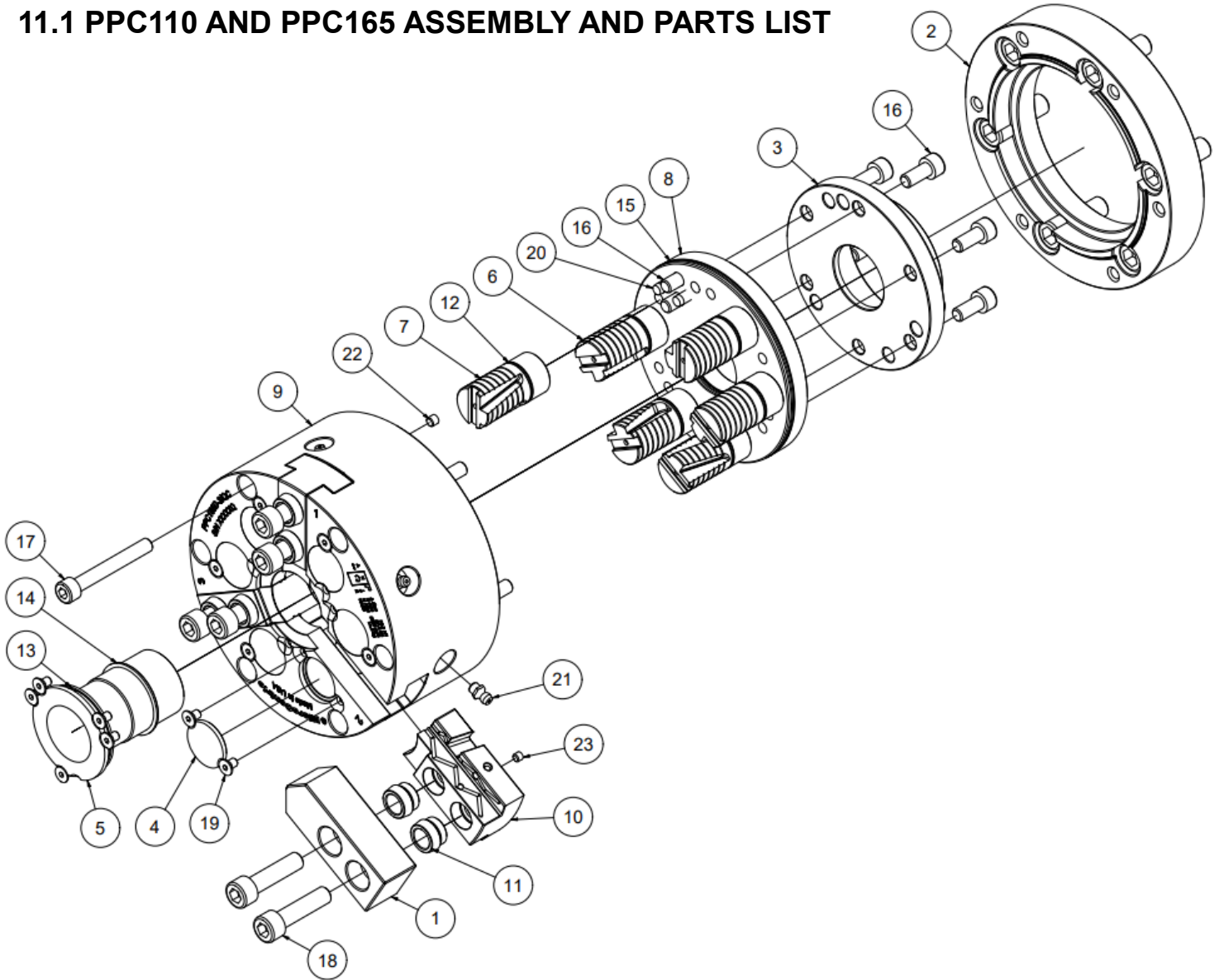

ITEM	QTY	TITLE
1	1	TOP JAW BLANK
2	1	ADAPTER
3	1	DRAW TUBE CONNECTOR
4	6	ACTUATOR DISK
5	1	CENTER SEAL
6	3	ACTUATOR
7	3	ACTUATOR
8	1	PISTON
9	1	BODY
10	3	MASTER JAW
11	6	QC BUTTON
12	6	O-RING

ITEM	QTY	TITLE
13	1	O-RING
14	2	O-RING
15	1	O-RING
16	18	SOCKET HEAD CAP SCREW
17	6	SOCKET HEAD CAP SCREW
18	6	SOCKET HEAD CAP SCREW
19	12	FLAT HEAD CAP SCREW
20	12	DOWEL PIN
21	6	GREASE FITTING
22	3	EXPANSION PLUG
23	6	EXPANSION PLUG

11.2 PPC210, PPC250D, PPC300D106 ASSEMBLY AND PARTS LIST

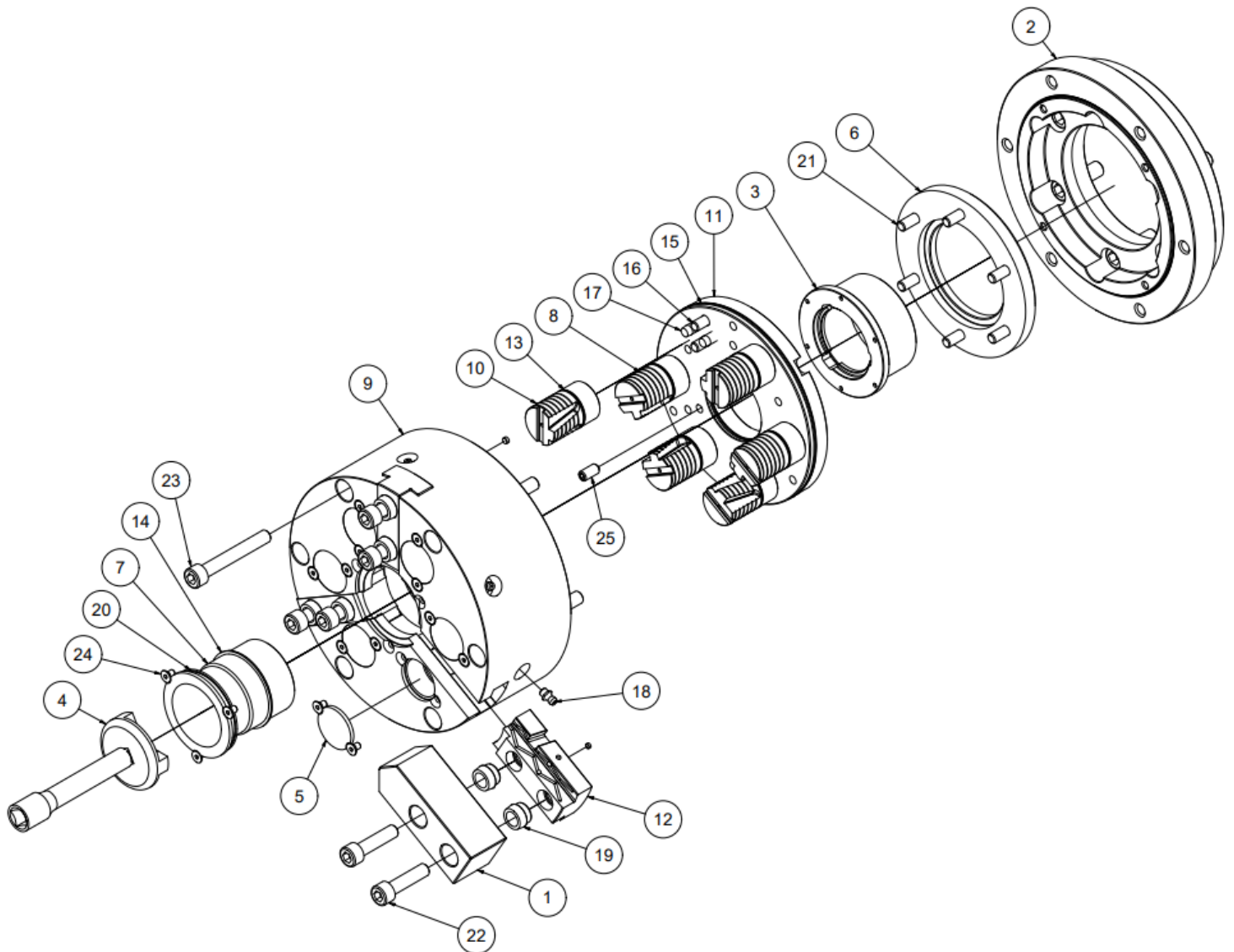

ITEM	QTY	TITLE
1	3	TOP JAW BLANK
2	1	ADAPTER
3	1	DRAW TUBE CONNECTOR
4	1	DTC WRENCH
5	6	ACTUATOR DISK
6	1	RETAINER
7	1	CENTER SEAL
8	3	ACTUATOR
9	1	BODY
10	3	ACTUATOR
11	1	PISTON
12	3	MASTER JAW
13	6	O-RING

ITEM	QTY	TITLE
14	2	O-RING
15	1	O-RING
16	12	SOCKET HEAD CAP SCREW
17	12	DOWEL PIN
18	6	GREASE FITTING
19	6	QC BUTTON
20	1	O-RING
21	6	SOCKET HEAD CAP SCREW
22	6	SOCKET HEAD CAP SCREW
23	6	SOCKET HEAD CAP SCREW
24	15	FLAT HEAD CAP SCREW
25	3	BALL PLUNGER

12.0 PPC CHUCK MAINTENANCE

12.1 LUBRICATING PPC CHUCKS

1. Before applying lubrication to the chuck, the chuck should be actuated and set in the unclamped (jaws fully open) position.
2. Recommended lubricant: Kluber Altemp QN B 50
3. Apply lubricant with a grease gun (3 to 5 cc) to each grease fitting on the OD of the chuck body.
4. After applying lubricant to all fittings, cycle the chuck (open and close the chuck) several times to distribute the lubricant to all sliding surfaces.
5. Wipe away any excess grease which has seeped out of the master jaw slots.

12.2 FREQUENCY OF LUBRICATION

1. PPC chucks should be lubricated at least once daily.
2. Chucks operated at high speed or are exposed to a high volume of water soluble cutting oil should be lubricated several times each day.
3. Chucks which are installed on machines running around the clock, should be lubricated at the start of each shift .

12.3 DISASSEMBLY OF PPC CHUCKS

1. After removing the chuck from the machine, set the chuck (without the adapter plate) on its rear face.
2. Remove the top jaws from the chuck.
3. Remove the center housing by unfastening the (3) flat head screws holding down the housing.
4. Remove the (3) cover disks by unscrewing the (6) flat head screws (2 per disk) securing the disks.
5. Using (2) blocks of equal height (or parallels), support the rear face of the chuck body. Make sure the blocks are clear of the piston bore.
6. With a brass (or other soft) plug approximately 3/4" (19mm) diameter, alternately tap the top face of each actuator to slide the piston assembly out of the chuck body. Use a mallet to tap the plug.
7. Once the piston assembly has been removed from the chuck body, remove each master jaw.
8. If the master jaws are tight, use a brass plug to tap each jaw out of the chuck body.



WARNING

PPC chucks must be lubricated on a regular basis to maintain long term accuracy and performance. Inadequate lubrication reduces gripping force and affects the chuck's repeating accuracy. Inadequate lubrication will also cause excessive wear and seizure.

IMPORTANT

Do not disassemble actuators from the piston, as they are position pinned in place.

IMPORTANT

Before applying lubrication to the chuck, the chuck should be actuated and set in the unclamped (jaws fully open) position.



CAUTION

PPC chucks should be disassembled, cleaned, lubricated, and reassembled at least once every 6 months or every 100,000 cycles. Chucks that are used to machine cast iron or sintered parts should be disassembled more frequently (at least every 2 to 3 months).

12.4 CLEANING OF PPC CHUCKS

1. After the chuck has been disassembled, remove all sludge and buildup on the sliding surfaces of the chuck body, actuators, and master jaws.
2. Clean off any buildup with fine emery paper.
3. Degrease all components in mineral spirits or other solvent.
4. Remove all residue of the solvent and keep each component clean until reassembly.

12.5 REASSEMBLY OF PPC CHUCKS

1. After all the chuck's components have been thoroughly cleaned, set the chuck face up on a bench.
2. Inspect all O-Rings and replace any which exhibit signs of wear. It is recommended to lubricate all O-rings with a lubricant such as Parker Super O-Lube.
3. Apply a liberal amount of grease such as Kluber Altemp QN B 50 to all surfaces of master jaw no.1. Slide master jaw no. 1 into the jaw slot which is marked slot no.1. The jaw should slide freely into the jaw slot with only hand pressure. If the jaw is tight going into the jaw slot remove the jaw, and make sure any buildup has been removed from both the jaw slot and master jaw. After cleaning, degrease the chuck body and master jaw again with a solvent. Apply lubricant to the master jaw and insert the jaw into the chuck body as outlined above.
4. Repeat this procedure for the other master jaws.
5. Turn the chuck face down with jaw slot no. 1 at 12 o'clock.
6. Apply an even coat of grease to the ID of the piston bore.
7. Liberally coat each actuator with grease. Coat the OD and both sides of the key which engages into the master jaw.
8. Turn the piston so that the rear side is facing up. Rotate the piston to align the letter stamped on its rear face with jaw slot no. 1.
9. Insert the piston assembly into the chuck by first inserting the 3 actuators into the bores in the chuck body. Then slide the piston assembly towards the face of the chuck until the actuators contact the master jaws.
10. Turn the chuck body over and support it on the blocks (or parallels) used to disassemble the chuck.

IMPORTANT

All components must be thoroughly cleaned and degreased before reassembly. Perform all assembly work on a clean bench in clean surroundings to prevent dirt and other contaminants from getting into the chuck.



CAUTION

When reassembling PPC chucks make sure each master jaw is mounted into the jaw slot with a corresponding number. Also make sure to align the piston assembly correctly so that the letter stamped on the back face of the piston is in line with jaw slot no. 1.

11. Looking into the three actuator bores on the face of the chuck, engage the slot of each master jaw into the actuator key.
12. Take the chuck off the blocks and push the piston assembly fully into the chuck body. The piston should slide into the chuck body freely, however, it may be necessary to tap the rear face of the piston assembly with a soft hammer to bring the assembly fully into the chuck body. Tap the rear face of the piston in a circular motion to prevent the piston from cocking.
13. Replace the 3 actuator disks on the face of the chuck. Secure each disk with a flat head cap screw. Make sure the top face of the screws are below the face of the chuck.

13.0 TROUBLE SHOOTING GUIDE

If your PPC chuck malfunctions, immediately stop the machine and refer to this trouble shooting guide for possible causes and ways to remedy the problem.

PROBLEM	POSSIBLE CAUSE	SUGGESTED REMEDY
The chuck does not operate.	A component inside the chuck (master jaw or actuator) is broken.	Disassemble chuck and contact MicroCentric for replacement or repair of the component or chuck.
	The master jaw slides or actuators are seized.	Disassemble the chuck to free the seized components by cleaning the chuck and removing buildup that has embedded itself onto the chuck's components and lubricate the chuck.
The master jaws do not stroke fully.	Swarf or dirt has built up inside the chuck.	Disassemble, clean, and lubricate the chuck.
	Improper assembly.	Ensure all parts have been reassembled correctly.
	The draw tube connector or draw tube is loose.	First check that the draw tube connector is fully threaded onto the draw tube. If the problem persists remove the chuck and tighten the draw tube onto the hydraulic actuator.
Workpiece slips.	Insufficient master jaw stroke.	Rebore top jaws so that the workpiece is clamped in the middle of the chuck's total jaw stroke.
	Insufficient clamping force.	Increase the hydraulic pressure to the cylinder within recommended limits.
	Machined clamping diameter in top jaw does not match workpiece diameter.	Rebore top jaws accordingly.
	Cutting force is too high.	Reduce cutting force.
	Insufficient lubrication to the chuck.	Lubricate the chuck according to the schedule and procedure outlined in Section 12.1 & 12.2.
	Spindle speed is too high.	Reduce spindle speed.
Excessive Vibration	Unequal weight distribution.	Counterbalance as required.
Excessive workpiece runout (concentricity) after machining.	OD of chuck is running out, (mounting screws not tight).	Indicate OD of chuck and true chuck to within specifications given in Section 9.0. Also make sure mounting screws are tightened properly.
	Chips, dirt, or other foreign material is embedded in clamping surface of top jaw.	Remove foreign material and/or rebore top jaws.
	Mounting screws of top jaws have not been adequately tightened.	Tighten mounting screws to torque specifications given in Section 4.0.
	Top jaws have not been properly machined (loaded).	Check that the loading ring or plug is not being deformed due to high clamping force. Review procedures outlined in Section 7.4.
	Top jaw is deformed during clamping due to excessive height and/or excessive clamping force.	Review the design of the top jaw, reducing the height of the jaw and lowering draw tube force.
	Workpiece is deformed during clamping by excessive clamping force.	Reduce draw tube force. Also evaluate the design of the top jaws to reduce jaw height and jaw mass to reduce effects of centrifugal force.

NOTES

 **MicroCentric**

**MicroCentric GmbH
Ringstrasse 134
70839 Gerlingen / Germany
Tel. 0049 (0) 7156 / 17819-0
Fax 0049 (0) 7156 / 17819-20
E-Mail: info@microcentric.de**

www.microcentric.de